



**P-32 / P-32+**  
ADVANCED SCREED CONTROL  
FOR ASPHALT PAVERS





## Topcon's Next Generation of Advanced Screed Control

- 3.5 in. color graphics LCD
- Compatible with previous generation System Five configurations
- Waterproof and IP67 rated
- Rugged cable design with strong strain relief
- Operate both sides of the screed from one control box

Topcon continues its long tradition of innovation with the P-32/P-32+ for asphalt pavers. For decades, the Topcon System Five solution for paving has been the industry's premier non-contacting screed control system. Featuring durable and time-tested components, such as Sonic Trackers, cross slope sensors, control boxes and the Trackerjack laser receiver, Topcon has introduced the successor of System Five with the P-32/P-32+ asphalt paver system.

### GC-35 Control Box

Topcon has an exciting control box for its 2D asphalt paver system which are rugged and waterproof with an IP67 environmental rating and can be sold on new pavers or as an upgrade to the System Five 9256 control boxes. The GC-35 includes a new mounting bracket, cables and a heavy duty double shelled carrying case.

The control boxes feature superior design, a faster processor and better on-screen options. The side-mounted cable connectors – versus bottom mounted – help keep cables away from moving parts on the paver. The increased processor speed and improved on-screen options make the system run faster and easier.

### Sonic Averaging System

The Topcon Sonic Averaging System has been the paving industry's first choice as a non-contacting replacement to the conventional mechanical ski. The Sonic Averaging System is comprised of an aluminum beam with four Sonic Trackers which continuously measure the elevation over the surface, automatically averaging and adjusting the tow point cylinder. The Sonic Averaging System is convenient, maneuverable and produces a great finished surface.



### GC-35 Paver System Control Box

With a 3.5 in. color graphics LCD, the display is easy to see day or night. View elevation and slope values for both sides of the screed from either side. Calibrating the system is much easier with on-screen menu choices and is faster than using the previous generation of control boxes.

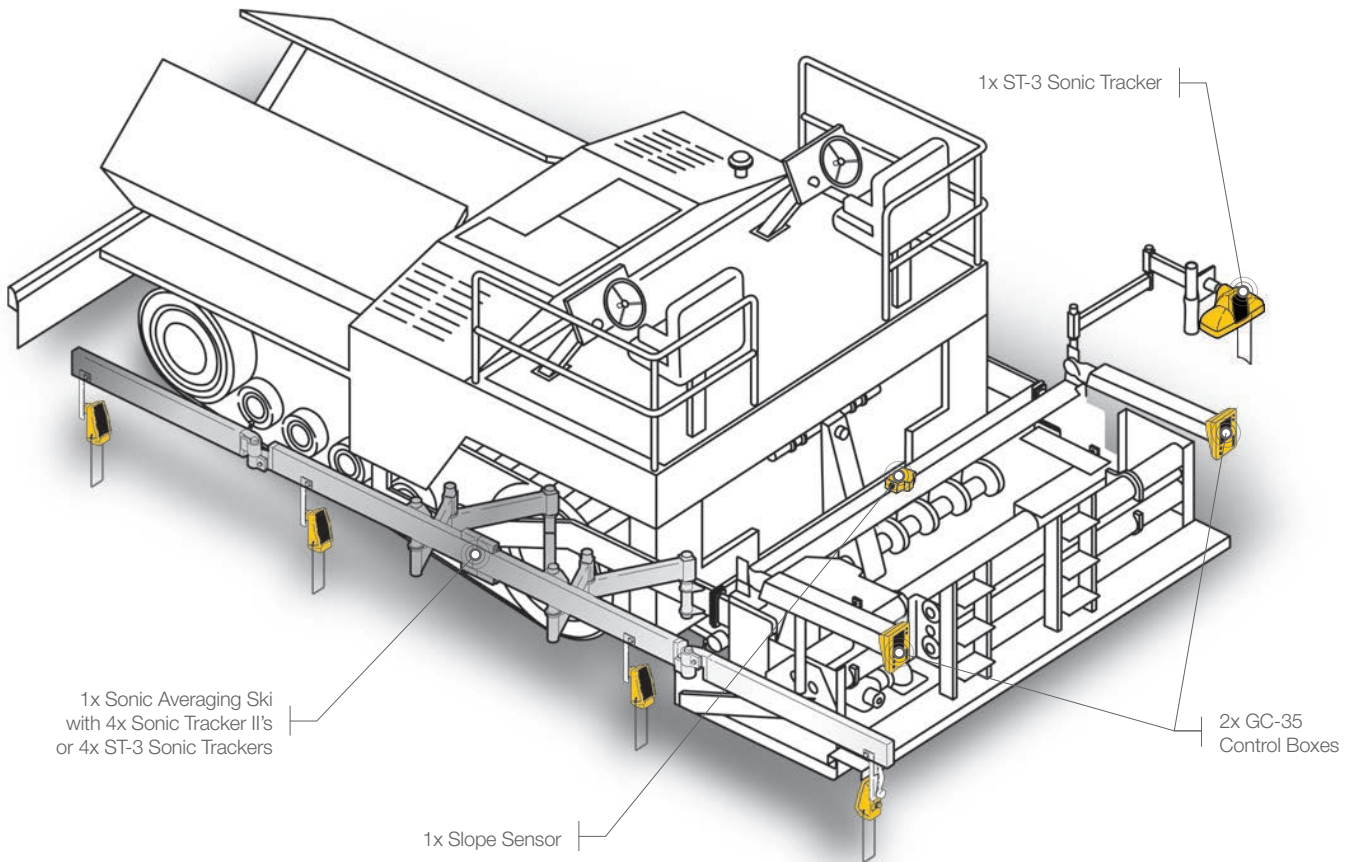

| GC-35 Control Box      |  |
|------------------------|--|
| Supply Voltage         | 10 to 30 VDC   |
| Supply Current         | 10.5 A max. operating current  |
| Switch Output Power    | 5 A sensor output<br>10 A valve output<br>10 A combined output   |
| Ports                  | USB<br>RS-485<br>RS-232<br>2x CAN<br>External Auto Input   |
| Display Panel          | 240 x 320 color LCD  |
| Housing                | Cast aluminum  |
| Weight                 | 1 kg   |
| Operating Temp         | -40°C to 80°C  |
| ST-3 Sonic Tracker     |  |
| Target Range           | 14 in. to 36 in.   |
| Dust/Water Rating      | IP67 / IP69K   |
| Connectors             | 11 Pin Bayonet<br>Shell Size 18  |
| Operating Temp         | 0°C to 80°C  |
| Weight                 | 1.3 kg   |
| Compatibility          | Sonic Tracker II<br>Connector/Cable<br>GC-35 for Stringline<br>Mode and Surface Mode<br>Other Control Boxes<br>Surface Mode Only |
| Dual Port Slope Sensor |  |
| Range                  | ± 0-20% Slope  |
| Resolution (High)      | ± 0.00625% Slope   |
| Operating Temp         | -20°C to 80°C  |
| Weight                 | 600 g  |
| Network                | RS-485 proprietary port  |



### GC-35 Control Box

- Waterproof and IP67 rated
- Backward compatible with System Five paver systems
- Designed with side mount connectors
- Faster processor and easy performance menu access
- Operate both sides of the screed from one control box

### ST-3 Sonic Tracker

- Waterproof and IP67 rated
- Sideway offset indication on stringline
- Flat detection range on stringline
- Smoother and faster response
- Twice as fast detection speed

### Dual Port Slope Sensor

- Exclusive anti-slosh ceramic technology
- Completely sealed internal electronics
- Rugged cast housing
- Insensitive to vibration
- Improved accuracy over extended temperature range

### Trackerjack Laser Receiver

- 360° gapless receiving
- Motorized receiver gets on-grade and “locks-on” to keep it there
- Bright grade indication LED's display continuous grade information
- Compatible with all Topcon lasers



For more information:  
[topconpositioning.com/p-32](http://topconpositioning.com/p-32)

Specifications subject to change without notice.  
©2016 Topcon Corporation All rights reserved.  
7010-2130 C 2/16

Get in touch today:  
**1300 867 266**  
[info@positionpartners.com.au](mailto:info@positionpartners.com.au)  
[www.positionpartners.com.au](http://www.positionpartners.com.au)  
Australia • New Zealand • SE Asia



Shaping New Dimensions